

# Modelling Wind Speed in Semarang City, Indonesia using Adaptive Neuro Fuzzy Inference Systems (ANFIS) Based on Stepwise Procedure

Sugito<sup>1</sup>, Alan Prahutama<sup>2</sup>, Dwi Ispriyanti<sup>3</sup>, Mustafid<sup>4</sup>, Diah Safitri<sup>5</sup>  
<sup>1,2,3,4,5</sup>Department of Statistics, Diponegoro University, Semarang, Indonesia

**Abstract-**Winds have a negative and positive impact on everyday life. Negative impacts in everyday life such as the disruption of the flight process. While the positive impact that can be generated for example, the wind is used as a source of energy. Therefore it is necessary to forecast method to predict wind speed. Semarang is the capital of Central Java province located in the northern part of Java island which became the center of Central Java's economy in Indonesia. Therefore research is needed to forecast wind speed in Semarang, Indonesia. The most commonly used forecasting method is the Autoregressive Integrated moving average (ARIMA). Modeling using ARIMA is a linear approximation that requires assumptions. One of the fuzzy-based forecasting methods that does not require assumptions is the Adaptive Neuro Fuzzy Inference System (ANFIS). The stages in ANFIS used in this study using Stepwise procedure. The first procedure is performed with the selection of input variables, followed by selection of membership numbers. The final step is the determination of membership function. The results obtained in the model of wind speed in Semarang is ANFIS model with the number of inputs as much as 2, membership number 3 and membership function is Gauss. The lowest RMSE in-sample and out-sample values are 0.000481 and 0.00378.

**Keywords –** Wind Speed, ANFIS, Stepwise Procedure.

## I. INTRODUCTION

Semarang City, the capital of Central Java Province, is one of strategically located big cities because it is in the middle of the northern coast of Java. The city coordinate is of 6050' - 7010' S and 109035' – 110050' E with an area of 373.7 km<sup>2</sup>, making the climate of this city tropical. As a tropical area, the climate in Semarang has high temperature and humidity. In addition, since this city is located close to the sea, it also has a high rainfall. Even, the rains in this city are frequently accompanied by strong winds. These natural phenomena require people in this city to always be alert [1].

According to Meteorological, Climatological, and Geophysical Agency (BMKG) of Semarang City [2] in January 2016 there were 34 cases of tornado in Central Java, while the occurrence of tornado will commonly reduce when the peak of rainy season is approaching. In February 2017, BMKG of Semarang City estimated that there would be rains and strong winds in Central Java, particularly in Semarang. This is due to the presence of low pressure in Northern Australia, causing the air to pass through Central Java resulting in rainfall. Rainfall particularly occurs in highland (mountainous regions), triggering cumulonimbus clouds which are usually accompanied by gusty winds at 40 kilometers per hour and lightning that could endanger national aviation activities [3]. Thus, the forecasting of wind speed is necessary as an early warning system in aviation industry. In addition to the negative effects arising from wind, there are also positive effects of wind, one of which is as a form of energy source.

One of the statistical methods employed in modeling and forecasting is Autoregressive Integrated Moving Average (ARIMA). ARIMA is a linear approach, meaning that ARIMA requires assumptions to be met, including the data shall be stationary and the residuals shall be white noise and normally distributed. Some of the modeling procedures using ARIMA are stationary test, model identification, parameter testing and model assumption testing. Since the assumptions of ARIMA are strict, failure in meeting these assumptions may result in a biased forecasting value. Therefore the approach that can be used apart from linear approach is nonlinear approach. One of the forecasting methods with a nonlinear approach that does not require assumptions is Adaptive Neuro-Fuzzy Inference System (ANFIS). ANFIS or Adaptive Neuro-Fuzzy Inference System is one hybrid system that combines neural network and fuzzy logic. In addition, ANFIS is a functional architecture that is similar to Sugeno fuzzy rule-based model. The architecture of ANFIS is also similar to neural networks with radial functions with certain limitations. Several things to pay attention to in ANFIS modeling are the determination of input, determination of membership function and determination of the activation function to be used. The activation functions can make use of Gaussian, Gbell, Trapezoidal, and Triangular functions. A study related to wind speed modeling using ANFIS is one

conducted by Salim et. al [4]. which modeled wind speeds on the eastern coast of Egypt using ANFIS. The results from the model showed more accuracy than previous studies. In addition, there were a number of studies related to the modeling of wind speed based on neural network and fuzzy such as Khosravi et. al [5], Asghar and Liu [6]. This paper analyzed the modeling of wind speed forecasting in Semarang City because this city is the largest city in Central Java that is located on the coastal area. The novelty of this paper is the ANFIS modeling procedure was not based on trial and error, but this used stepwise procedure. The stepwise procedure was by inputting variable of lag 1, then lag 2, then lag 3, then the combination of these lags. This was then followed by determining the number of membership functions, starting from two, then three. After that, the membership functions were determined. The membership functions included Gaussian, Gbell, Trapezoidal, and Triangular functions. The data used in this study were obtained from BMKG of Semarang City for the period of August 2015 until August 2017. The forecasting to be produced is daily forecasting.

## II. PROPOSED ALGORITHM

### 2.1 Adaptive Neuro Fuzzy Inference System (ANFIS)

Fuzzy set is a set where the membership of each element has no clear boundaries [7]. The concept of this set is in contrast to classical set. Input space is mapped into the value or degree of membership through a function called membership function (MF). Membership function defines how each point in the input space is mapped into the value or degree of membership between 0 and 1.

Membership function can use Triangular, Trapezoidal, Gaussian, or Generalized Bell or Gbell, Sigmoidal, and Left-Right or LR functions as follows [7]:

Triangular

$$f(y; a, b, c) = \max\left(\min\left(\frac{y-a}{b-a}, \frac{c-y}{c-b}\right), 0\right)$$

where, a and c are the parameters at the feet of triangle and b is the peak  
 Trapezoidal

$$f(y; a, b, c, d) = \max\left(\min\left(\frac{y-a}{b-a}, 1, \frac{d-y}{d-c}\right)\right)$$

Gaussian

$$f(y; \mu, \sigma) = \exp\left(-\frac{1}{2}\left(\frac{y-\mu}{\sigma}\right)^2\right)$$

where, parameter  $\mu$  is the center and  $\sigma$  is the width of function

Gbell

$$f(y; a, b, c) = \frac{1}{1 + \left|\frac{y-c}{a}\right|^{2b}}$$

where, parameter c is the center, a is the width of function, and b is the crossover point at the slope.

Sigmoidal

$$f(y; a, c) = \frac{1}{1 + \exp[-a(y-c)]}$$

where a is the control slope at the crossover point  $x = c$

Left-Right

$$f(y; a, c, b) = \begin{cases} \max\left(0, \sqrt{1-y^2}\right)\left(\frac{c-y}{a}\right); & y \leq c \\ \exp\left(-|y|^\beta\right)\left(\frac{c-y}{a}\right); & y \geq c \end{cases}$$

Fuzzy inference system is a computational framework based on fuzzy set theory, fuzzy rules in the form of IF-THEN, and fuzzy [8].

In addition, fuzzy model can also be used as a substitute of perceptron with multiple layers. In this case, the system can be categorized into 2 groups: a group of artificial neural networks with fuzzy weights and fuzzy activation

functions and another group of neural networks with fuzzified input in the first or second layer, and unfuzzified weights on the artificial neural networks. Neuro fuzzy belongs to the second group [7].

ANFIS or Adaptive Neuro-Fuzzy Inference System is one of the hybrid systems that combines neural network and fuzzy logic. ANFIS is a architecture that is functionally similar to Sugeno fuzzy rule-based model. The architecture of ANFIS is also similar to neural networks with radial functions with few limitations. In other words, ANFIS is a method of which the setting of the rules makes use of learning algorithm to a set of data and allows rules to adapt.

2.2. Architecture of ANFIS –

The architecture of ANFIS (Figure 1) uses two rules on Sugeno fuzzy rule-based model [8] namely:

Rule I : If x1 is A1 and x2 is B1 Then f1 = c11x1 + c12x2 + c10

Rule II : If x1 is A2 and x2 is B2 Then f2 = c21x1 + c22x2 + c20

If  $\alpha$  the predicates for both rules are w1 and w2, then the weighted average is:

$$y = \frac{w_1 y_1 + w_2 y_2}{w_1 + w_2} = \bar{w}_1 y_1 + \bar{w}_2 y_2$$

ANFIS networks consist of the following layers (Jang, 1997):

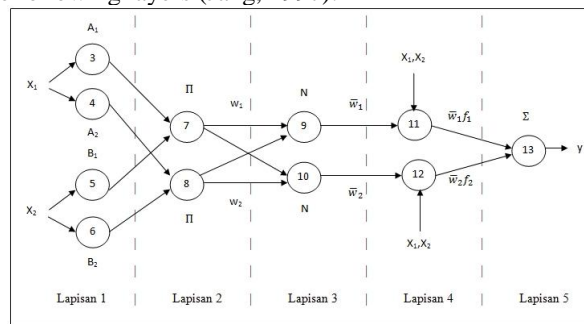

Figure 1. Architecture of ANFIS

The first layer is in the form of the degree of membership that is given by the input membership function. The membership function is Gbell where {a, b, c} are the parameters, usually b = 1. The parameters in this layer are

$$\mu(x) = \frac{1}{1 + \left| \frac{x-c}{a} \right|^{2b}}$$

called as premise parameters, where

The second layer is a fixed neuron whose output is the result from the input. Each node represents the predicates of the i rule. This layer is called firing strength for  $w_i = \mu_{A_i} \mu_{B_i}$ , where  $\mu_{A_i}$  is the membership function of A on the i rule and  $\mu_{B_i}$  is the membership function of B

$$\bar{w}_i = \frac{w_i}{w_1 + w_2}$$

on the i rule. The third layer is called as normalised firing strength for

The fourth layer, each neuron in the fourth layer is an adaptive node to an output. Where  $\bar{w}_i$  is normalised firing strength on the third layer and {ci1, ci2, ci0} are the parameters of the neuron. The parameters of this layer are called as consequent parameters where  $\bar{w}_i y_i = \bar{w}_i (c_{i1} x_1 + c_{i2} x_2 + c_{i0})$ . The fifth layer is fixed node, i.e. the sum of all inputs where

$$O_{5,i} = \sum_i \bar{w}_i f_i = \frac{\sum_i w_i f_i}{\sum_i w_i}$$

In the implementation, ANFIS uses hybrid learning that combines Least Square Estimator (LSE) and error backpropagation (EBP). At forward propagation, the network input will propagate forward to the fourth layer, where the parameters cij will be identified using LSE. Meanwhile at backward propagation, the error will propagate backward and the parameters {ai, bi, ci} will be fixed by using gradient-descent method.

### III. EXPERIMENT AND RESULT

The following is the scatter plot of this research finding.

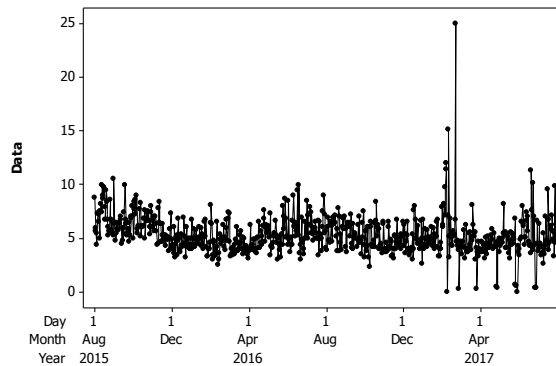

Figure 2. Scatter plot of wind speed data from August 2015 to August 2017

The first step in ANFIS modeling for wind speed data is to specify the PACF plot, followed by determining the input variables based on lag Autoregressive. Then, the number of membership is determined, while the membership functions used are Gbell, Gaussian, Triangular and Trapezoidal and the number of iterations. This is then followed by ANFIS processes such as fuzzification, fuzzy logic operation, the activation of normalization degree, and defuzzification. In this study, the data were divided into two data insample (from August 2015 to July 2017) and data outsample (August 2017).

#### 3.1. ANFIS modeling based on input variabel

based on the pacf plot in figure 3, it can be seen that the cut off is after lag 2 so that the input variables used for anfis modeling are lag 1, lag 2 and lag 3. in this paper, the inputs used for anfis modeling were lag 1, lag 2, lag 3 and lag 1 with lag 2.

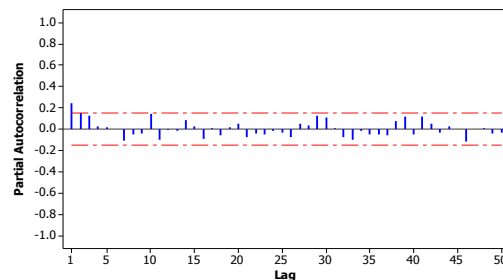

Figure 3. Scatter Plot Of PACF Of Wind Speed

there were two memberships used, while the activation function used was gaussian.

In order to get parameters that minimize error, data training using learning algorithm Least Square and Backpropagation was carried out. This algorithm was expected to result in forward consequent parameters with Least Square algorithm and backward premise parameters with Backpropagation algorithm. The premise parameters obtained through the hybrid learning process are presented in Table 2. According to Table 2, the Gaussian function to obtain membership degree as follow as:

Table1. Membership functions (MF) in every lag

MF for Lag 1	MF for Lag 2
$f_{11} = \exp \left\{ -\frac{1}{2} \left( \frac{y_{t-1} - 6.091}{1.752} \right)^2 \right\}$	$f_{11} = \exp \left\{ -\frac{1}{2} \left( \frac{y_{t-2} - 4.665}{1.479} \right)^2 \right\}$
$f_{21} = \exp \left\{ -\frac{1}{2} \left( \frac{y_{t-1} - 4.947}{1.668} \right)^2 \right\}$	$f_{21} = \exp \left\{ -\frac{1}{2} \left( \frac{y_{t-2} - 6.076}{1.572} \right)^2 \right\}$

MF for Lag 3	MF for Lag 1 and lag 2
$f_{11} = \exp\left\{-\frac{1}{2}\left(\frac{y_{t-3}-5.945}{1.465}\right)^2\right\}$ $f_{21} = \exp\left\{-\frac{1}{2}\left(\frac{y_{t-3}-4.708}{1.618}\right)^2\right\}$	$f_{11} = \exp\left\{-\frac{1}{2}\left(\frac{y_{t-1}-6.095}{1.456}\right)^2\right\}$ $f_{21} = \exp\left\{-\frac{1}{2}\left(\frac{y_{t-1}-4.789}{1.49}\right)^2\right\}$ $f_{12} = \exp\left\{-\frac{1}{2}\left(\frac{y_{t-2}-6.184}{1.329}\right)^2\right\}$ $f_{22} = \exp\left\{-\frac{1}{2}\left(\frac{y_{t-2}-4.69}{1.285}\right)^2\right\}$

On the fourth layer, the results were in the form of consequent parameters that could minimize error. The consequent parameters of the iterated result through the learning algorithm are presented in Table 4. According to the rules established from the consequent parameters, the estimated forecasting model for wind speeds in Semarang City using ANFIS method for each input is as shown in Table 5.

For Input Lag 1 as follow as:

$$\hat{y}_t = \bar{w}_1(-0.0336y_{t-1} + 7.027) + \bar{w}_2(0.3688y_{t-1} + 2.036)$$

$$w_1 = \exp\left\{-\frac{1}{2}\left(\frac{y_{t-1}-6.091}{1.752}\right)^2\right\}; \quad w_2 = \exp\left\{-\frac{1}{2}\left(\frac{y_{t-1}-4.947}{1.668}\right)^2\right\}$$

For Input Lag 2 as follow as:

$$\hat{y}_t = \bar{w}_1(-0.1596y_{t-2} + 4.4) + \bar{w}_2(-0.1775y_{t-2} + 7.99)$$

$$w_1 = \exp\left\{-\frac{1}{2}\left(\frac{y_{t-2}-4.665}{1.479}\right)^2\right\}; \quad w_2 = \exp\left\{-\frac{1}{2}\left(\frac{y_{t-2}-6.076}{1.572}\right)^2\right\}$$

For input lag 3 as follow as:

$$\hat{y}_t = \bar{w}_1(0.212y_{t-3} + 4.897) + \bar{w}_2(0.045y_{t-3} + 4.31)$$

$$w_1 = \exp\left\{-\frac{1}{2}\left(\frac{y_{t-3}-5.945}{1.465}\right)^2\right\}; \quad w_2 = \exp\left\{-\frac{1}{2}\left(\frac{y_{t-3}-4.708}{1.618}\right)^2\right\}$$

For input lag 1 and Lag 2 as follow as:

$$\hat{y}_t = \bar{w}_1(0.06y_{t-1} - 0.04y_{t-2} + 6.035) + \bar{w}_2(0.42y_{t-1} - 0.19y_{t-2} + 3.48)$$

$$w_1 = \left[ \exp\left\{-\frac{1}{2}\left(\frac{y_{t-1}-6.095}{1.456}\right)^2\right\} \right] \left[ \exp\left\{-\frac{1}{2}\left(\frac{y_{t-1}-4.789}{1.49}\right)^2\right\} \right]$$

$$w_2 = \left[ \exp\left\{-\frac{1}{2}\left(\frac{y_{t-2}-6.184}{1.329}\right)^2\right\} \right] \left[ \exp\left\{-\frac{1}{2}\left(\frac{y_{t-2}-4.69}{1.285}\right)^2\right\} \right]$$

The RMSE values for each of the ANFIS models in lag 1, lag 2, lag 3 and lag 1 with lag 2 are as shown in Table 6. Based on the table, the lowest RMSE insampel value is in the ANFIS model with input lag 2. This model also resulted in the lowest RMSE outsampel value compared to the ANFIS models with other inputs.

Table 2. RMSE input for Lag 1, Lag 2, Lag 1 and 2 with 2 cluster

RMSE	Lag 1	Lag 2	Lag 3	Lag 1 dan 2
In-sample	0.0044823	0.002681	0.05522	0.010735
sOut-sample	0.055482	0.042785	0.344929	0.044984

### 3.2. ANFIS Modeling of Input Variabel Based on the Number of Membership

The next step after determining the best input lag model was to determine the number of membership. The previous ANFIS analysis has performed modeling using two memberships. Then, tests using 3 and 4 memberships were also

carried out. The estimated ANFIS Model with input lag 2 and 3 memberships is as follows:  $\hat{y}_t^{(1)} = c_{11}y_{t-2} + c_{10}$ ;  $\hat{y}_t^{(2)} = c_{21}y_{t-2} + c_{20}$ ; and  $\hat{y}_t^{(3)} = c_{31}y_{t-2} + c_{30}$ . Table 7 shows the initial value of premis parameter with input lag 2 and 3 memberships.

Table 3. Initial Value for Premis paarmeter with lag input 1 and 2 with 3 cluster

Input Lag 2		
$\sigma_{11} = 0.8394$	$\sigma_{21} = 1.147$	$\sigma_{31} = 1.046$
$\mu_{11} = 4.372$	$\mu_{21} = 6.758$	$\mu_{31} = 5.505$

The consequent parameters of the iterated result through the learning algorithm for the input lag 2 with 3 memberships are as follows:  $\hat{y}_t^{(1)} = 0.467y_{t-2} + 2.316$ ;  $\hat{y}_t^{(2)} = -0.174y_{t-2} + 7.97$  and  $\hat{y}_t^{(3)} = -0.946y_{t-2} + 9.94$ . Based on the rules established from these consequent parameters, the estimated ANFIS model with an input lag 2 with 3 memberships is as follows:

$$\hat{y}_t = \bar{w}_1\hat{y}_t^{(1)} + \bar{w}_2\hat{y}_t^{(2)} + \bar{w}_3\hat{y}_t^{(3)}$$

$$\bar{w}_i = \frac{w_i}{\sum_{i=1}^n w_i}$$

Whereas

$$w_1 = \exp\left\{-\frac{1}{2}\left(\frac{y_{t-2} - 4.372}{0.8394}\right)^2\right\}; \quad w_2 = \exp\left\{-\frac{1}{2}\left(\frac{y_{t-2} - 6.758}{1.147}\right)^2\right\} \quad \text{and} \quad w_3 = \exp\left\{-\frac{1}{2}\left(\frac{y_{t-2} - 5.505}{1.046}\right)^2\right\}$$

Based on ANFIS analysis, the best model is ANFIS with an input lag 2 with 3 memberships with the lowest RMSE in-sample value of 0.00048 and the lowest RMSE out-sample value of 0.0377. This is lower than ANFIS modeling with an input lag 2 and 2 memberships. The next step is ANFIS modeling with an input lag 2 with 4 memberships.

The estimated ANFIS model with 4 memberships is as follows:  $\hat{y}_t^{(1)} = c_{11}y_{t-2} + c_{10}$ ;  $\hat{y}_t^{(2)} = c_{21}y_{t-2} + c_{20}$ ;  $\hat{y}_t^{(3)} = c_{31}y_{t-2} + c_{30}$  and  $\hat{y}_t^{(4)} = c_{41}y_{t-2} + c_{40}$

Table 4. Initial Value for Premis Parameter with input lag 2 with 4 cluster

Input Lag 2			
$\sigma_{11} = 0.9415$	$\sigma_{21} = 0.8213$	$\sigma_{31} = 0.7557$	$\sigma_{41} = 0.8563$
$\mu_{11} = 6.601$	$\mu_{21} = 4.968$	$\mu_{31} = 4.197$	$\mu_{41} = 6.716$

The consequent parameters of the iterated result through the learning algorithm are as follows:  $\hat{y}_t^{(1)} = 0.084y_{t-2} + 2.32$ ;  $\hat{y}_t^{(2)} = 4.41y_{t-2} - 17.29$ ;  $\hat{y}_t^{(3)} = 0.357y_{t-2} + 5.672$ ;  $\hat{y}_t^{(4)} = 1.78y_{t-2} - 4.485$

ANFIS Model obtained with an input lag 2 with 4 memberships is as follows:

$$\hat{y}_t = \bar{w}_1\hat{y}_t^{(1)} + \bar{w}_2\hat{y}_t^{(2)} + \bar{w}_3\hat{y}_t^{(3)} + \bar{w}_4\hat{y}_t^{(4)}$$

whereas,

$$w_1 = \exp\left\{-\frac{1}{2}\left(\frac{y_{t-2} - 6.601}{0.9415}\right)^2\right\}; \quad w_2 = \exp\left\{-\frac{1}{2}\left(\frac{y_{t-2} - 4.968}{0.8213}\right)^2\right\}$$

$$w_3 = \exp\left\{-\frac{1}{2}\left(\frac{y_{t-2} - 4.197}{0.7557}\right)^2\right\}; \quad w_4 = \exp\left\{-\frac{1}{2}\left(\frac{y_{t-2} - 6.716}{0.8563}\right)^2\right\}$$

Based on the ANFIS analysis, the best model is ANFIS with an input lag 2 with 4 memberships with the lowest RMSE in-sample value of 760.005986 and the lowest RMSE out-sample value of 0.0962. Based on the analysis for the selection of the number of membership, the best model of ANFIS is with an input lag 2 with 3 memberships. The next step was to select the activation function of ANFIS model with an input lag 2 with 3 memberships. The activation functions consisted of Gbell, Trapezoidal and Triangular. The previous analysis used Gaussian activation function, where the Gaussian function was compared with other functions.

*3.3 ANFIS Modeling with Input Variabel of Lag 2 and 3 Memberships Based on Membership Functions.*

Based on the ANFIS analysis, the best model is ANFIS with an input lag 2 with 3 memberships with the lowest RMSE in-sample value of 0.000812 and the lowest RMSE out-sample value of 0.0594, with the following equation:

Table 5. Initial Value for Premis Parameter with input lag 2 with 3 cluster and Gbell MF

Gbell		
$a_{11} = 6.514$	$a_{12} = 6.335$	$a_{13} = 6.353$
$b_{11} = 1.655$	$b_{12} = 1.514$	$b_{13} = 1.488$
$c_{11} = 0.1295$	$c_{12} = 12.63$	$c_{13} = 25$
Triangular		
$a_{11} = 12.49$	$a_{12} = 0.6583$	$a_{13} = 12.45$
$b_{11} = 0.4329$	$b_{12} = 12.48$	$b_{13} = 24.99$
$c_{11} = 12.56$	$c_{12} = 25$	$c_{13} = 37.5$
Trapezoidal		
$a_{11} = -8.75$	$a_{12} = 3.046$	$a_{13} = 16.25$
$b_{11} = -3.75$	$b_{12} = 8.974$	$b_{13} = 21.25$
$c_{11} = 4.148$	$c_{12} = 16.25$	$c_{13} = 28.75$
$d_{11} = 8.735$	$d_{12} = 21.25$	$d_{13} = 33.75$

Parameter konsekuen untuk model ANFIS lag input 2 dengan jumlah keanggotaan 3 untuk berbagai fungsi aktivasi adalah sebagai berikut:

Table 6. The value of consequent parameter for ANFIS model for input lag 2, 3 number of membership with some of activation function

Activation Function	Consequent Parameter
Gbell	$\hat{y}_t^{(1)} = -0.094y_{t-2} + 4.7$ $\hat{y}_t^{(2)} = -0.363y_{t-2} + 13.3$ $\hat{y}_t^{(3)} = 2.535y_{t-2} - 58.57$
Triangular	$\hat{y}_t^{(1)} = 130.9y_{t-2} - 84.14$ $\hat{y}_t^{(2)} = -142.4y_{t-2} + 1793$ $\hat{y}_t^{(3)} = -135.7y_{t-2} + 3397$
Trapezoidal	$\hat{y}_t^{(1)} = -0.188y_{t-2} + 5.064$ $\hat{y}_t^{(2)} = -0.387y_{t-2} + 9.786$ $\hat{y}_t^{(3)} = 0.1877y_{t-2} + 0.0075$

Based on Table 6, it show that the RMSE value in Lag 2 with membership number 3 for membership functions Gbell, Triangular, Trapezoidal and Gaussian. Based on the lest RMSE value is using Gaussian function. The best model of ANFIS in wind modelling is using lag 2 with membership number 3 and Gaussian function.

Table 7. RMSE insample and outsample ANFIS model input Lag 2

RMSE	Lag 2 dengan jumlah keanggotaan 3			
	Gbell	Gaussian	Triangular	Trapezoidal
In-sample	0.0008122	0.000481	0.004329	0.007791
Out-sample	0.05941	0.00378	0.045395	0.104418

#### IV. CONCLUSION

Based on the results of the analysis and discussion using Adaptive Neuro-Fuzzy Inference System (ANFIS), the conclusions are as follows:

Based on input lag, the best ANFIS model is with input lag 2 variable, 2 memberships, and Gaussian membership function. The lowest RMSE in-sample and out-sample values are 0.004845 and 0.008008.

Based on the number of membership and membership function, the best ANFIS model is with input lag 2 variable, 3 memberships, and Gaussian membership function. The lowest RMSE in-sample and out-sample values are 0.000481 and 0.00378.

#### V. REFERENCE

- [1] Central Statistics Agency (BPS) Semarang City, Semarang Municipality in Figures 2016, Semarang, Indonesia, 2016.
- [2] Meteorological, Climatological, and Geophysical Agency (BMKG) of Semarang, Ahmad Yani Airport weather information, 2016.
- [3] D. Petkovic, S. Shamshirband, N.B. Anuar, M.L.M. Kiah and A. Gani, "Adaptive neuro fuzzy evaluation of wind farm power production as function of wind speed and direction", *Stoch Environ Res Risk Assess* (29), pp: 793-802, 2015.
- [4] O.M. Salim, M.A. Zohdy, H.T. Dorrah and A.M. Kamel, "Adaptive neuro-fuzzy short term wind speed forecasting for Egypt's East-Cost", *International Journal of Sustainable energy* (33)No.1, pp:16-34, 2014.
- [5] A. Khosravi, R.N.N. Koury, L. Machado and J.J.G. Pabon, "Prediction of wind speed and wind direction using artificial neural network, support vector regression and adaptive neuro fuzzy inference system", *Sustainable energy technologies and assessments* (25), pp:146-60, 2018.
- [6] A. B. Asghar and X. Liu, " Adaptive neuro fuzzy algorithm to estimate effective wind speed and optimal rotor speed for variable speed wind turbine", *Neurocomputing* (272), pp:495-504, 2018.
- [7] Jang, JSR., CT Sun, dan E Mizutani. 1997. *Neuro-Fuzzy and Soft Computing : A Computational Approach to Learning and Machine Intelligence*. London : Prentice-Hall, Inc.
- [8] L. Rafati, M.H. Ehrampoush, A. Talebi, M. Mokhtari, Z.K. Pisheh, and H.R. Dehghan. "Modelling the information of Ozone in the air by using Adaptive Neuro-Fuzzy Inference System (ANFIS) (Case Study: city of Yazd, Iran)", *Desert* 19-2, pp:131-135, 2014.