

Fabrication of Abrasive Jet Machine

Rajeev Ranjan

Department of Mechanical Engineering, Ramgarh Engineering College, Ramgarh, Jharkhand, India

Kumar Gaurav, Nitant Kachhap, Rajdeo Banra, Shubham Kumar, Kumar Agastya
*Department of Mechanical Engineering, B-Tech Final Year Student, Ramgarh Engineering College
Ramgarh, Jharkhand, india*

Abstract: Abrasive Jet Machining (AJM) is the process of material removal from a work piece by the application of a high speed stream of abrasive particles suspended in a gas medium from a nozzle. The material removal process is mainly caused by brittle fracture by impingement and then by erosion. The AJM will chiefly be used to cut shapes, drill holes and de-burr in hard and brittle materials like glass, ceramics etc. In this project, a model of the Abrasive Jet Machine was designed using CAD packages like AutoCAD and CATIA. Care was taken to efficiently use the available material and space. The machine was fabricated in the institute workshop with convectional machine tools like arc welding machine, hand drill, grinding machine using commonly available materials like mild steel sheet and rod, aluminum sheet, glue, polythene sheet ,glass fiber which are commonly available in the local market. Care has been taken to use less fabricated components, because, the lack of accuracy in fabricated components would lead to a reduced performance of the machine. The machine was be automated to have 3 axes travel using microcontroller and driver arrangement along with stepper motor. The different functional components of AJM are the machining chamber, work holding device, abrasive drainage system, compressor, air filter and regulator, abrasive nozzle, and mixing chamber with cam motor arrangement. The different components are selected after appropriate design calculations

Keywords -- Abrasive, Jet, Machining, nozzle, brittle.

1. INTRODUCTION

In old ages material remove from a work piece done with an edged cutting tool. The cutting tool is moved relative to the work piece for the purpose. The mechanism of material is related to plastic deformation and the consequent chip formation as shown in figure (1.1). The cutting tool is traditionally harder than the work piece. Use of such tools and processes of machining are satisfactory in most cases.

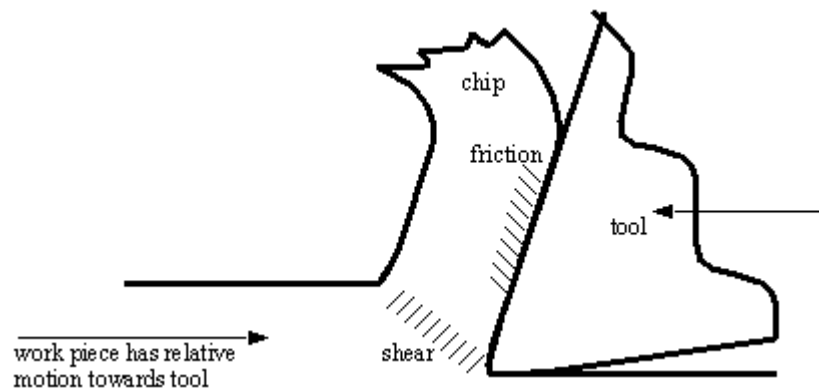

Fig-1.1

However, there are hard and brittle work materials for which the conventional cutting processes for material removal can not fulfill the requirements. For example, the production of fine holes with small diameter on thin brittle job is very difficult by conventional method. The techniques of piercing stamping and extrusion do not work satisfactorily on brittle materials because of their limited plasticity. These materials may develop cracks or may even crumble under such processes. Even the drilling of circular holes on brittle materials is difficult task, if conventional methods are employed. Techniques like abrasive jet machining (AJM), electro-discharge machining (EDM), laser beam machining (LBM), electro beam machining (EBM) and ultrasonic machining (USM) are some of the methods which are suggested for such situations. These processes are called unconventional machining processes.

The Abrasive jet machining (AJM) is one of the unconventional machining processes. And here we discuss about Abrasive Jet Machining (AJM)

II. HISTORY OF ABRASIVE JET MACHINING

In 1970's water jet was being started to be used as a source of cutting soft materials such as leather, frozen meat, thin Aluminium sheets etc... Later in the 1980's abrasives were being added to the water jet to increase the cutting action so that much high strength materials such as steel, cast iron can be machined through the process. This addition of abrasives led to the idea that if abrasives are made to impinge at high velocity on the material then material removal would take place. Thus abrasive jet machining evolved that used a nozzle for impinging the abrasive particles at high velocity on to the work material. Significant amount of research is carried on this process to increase the material removal rate and also on the type and shape of abrasives used for a particular type of material. The advantage of this process is that intricate shapes can be produced by this process but the material removal rate is rather low.

III. ABRASIVE JET MACHINING PRINCIPLE

Abrasive Jet Machining (AJM) is the removal of material from a work piece by the application of a high speed stream of abrasive particles carried in gas medium from a nozzle. The AJM process is different from conventional sand blasting by the way that the abrasive is much finer and the process parameters and cutting action are both carefully regulated. The process is used chiefly to cut intricate shapes in hard and brittle materials which are sensitive to heat and have a tendency to chip easily. The process is also used for drilling, de-burring and cleaning operations. AJM is fundamentally free from chatter and vibration problems due to absence of physical tool. The cutting action is cool because the carrier gas itself serves as a coolant and takes away the heat.

IV. EQUIPMENT

A schematic layout of AJM is shown in Figure. The main components being the compressor, air filter regulator, mixing chamber, nozzle and its holder, work holding devices and X-Y table. Air from the atmosphere is compressed by the compressor and is delivered to the mixing chamber via the filter and regulator. The mixing chamber contains the abrasive powders and is made to vibrate by an electric motor and cam arrangement. Then the abrasive particles are passed into a connecting hose leading to the nozzle. This abrasive and gas mixture emerges from the orifice of nozzle at high velocity. The feed rate of abrasive air is controlled by the amplitude of vibration of the mixing chamber. A pressure regulator installed in the system controls the gas flow and pressure. The nozzle is mounted on a plate which is screwed to the frame. The work piece is moved by moving the x-y table to control the size and shape of the cut. Dust removal equipment is necessary to protect the environment.

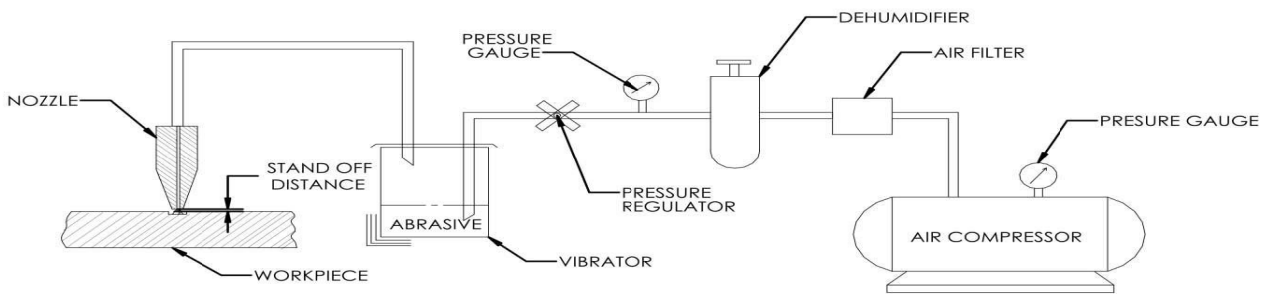

Fig-1- Layout of abrasive jet machine
Performance

The major variables affecting the performance parameters like material removal rate, machining accuracy etc. are as follows:-

The major variables that influence the rate of metal removal and accuracy of machining in this process are as follows:-

1. Composition and density of carrier gas
2. Types of abrasive
3. Size of abrasive grain
4. Velocity of abrasive jet

5. Flow rate of abrasive jet
6. Work piece material
7. Geometry, composition and material of nozzle
8. Nozzle tip distance (stand-off distance)
9. Shape of cut and operation type
10. Mixing ratio
11. Impingement angle

Table-1- Performance parameters standard values

I no.	Parameters	General values
1	Abrasive material	Al ₂ O ₃ / SiC / glass beads
2	Abrasive shapes	irregular / spherical
3	Abrasive size	10-50 μm
4	Mass flow rate	2 ~ 20 gm/min
5	Carrier gas Composition	Air, CO ₂ , N ₂
6	Air jet velocity	500 ~ 700 m/s
7	Pressure	2-10 bars
8	Flow rate	5-30lpm
9	Mixing ratio – mass flow ratio of abrasive to gas	Mabr/Mgas
10	Stand-off distance	0.5 ~ 5 mm
11	Impingement Angle	600 ~ 900
12	Nozzle– Material	WC / sapphire
13	Diameter	0.2 ~ 0.8 mm
14	Life	10 ~ 300 hours

V. OPERATING CHARACTERISTICS

The main performance measuring parameters of AJM are as follows

1. The material removal rate in gm/mm³ ,
2. The accuracy and surface finish of the machined surface
3. The nozzle wear rate

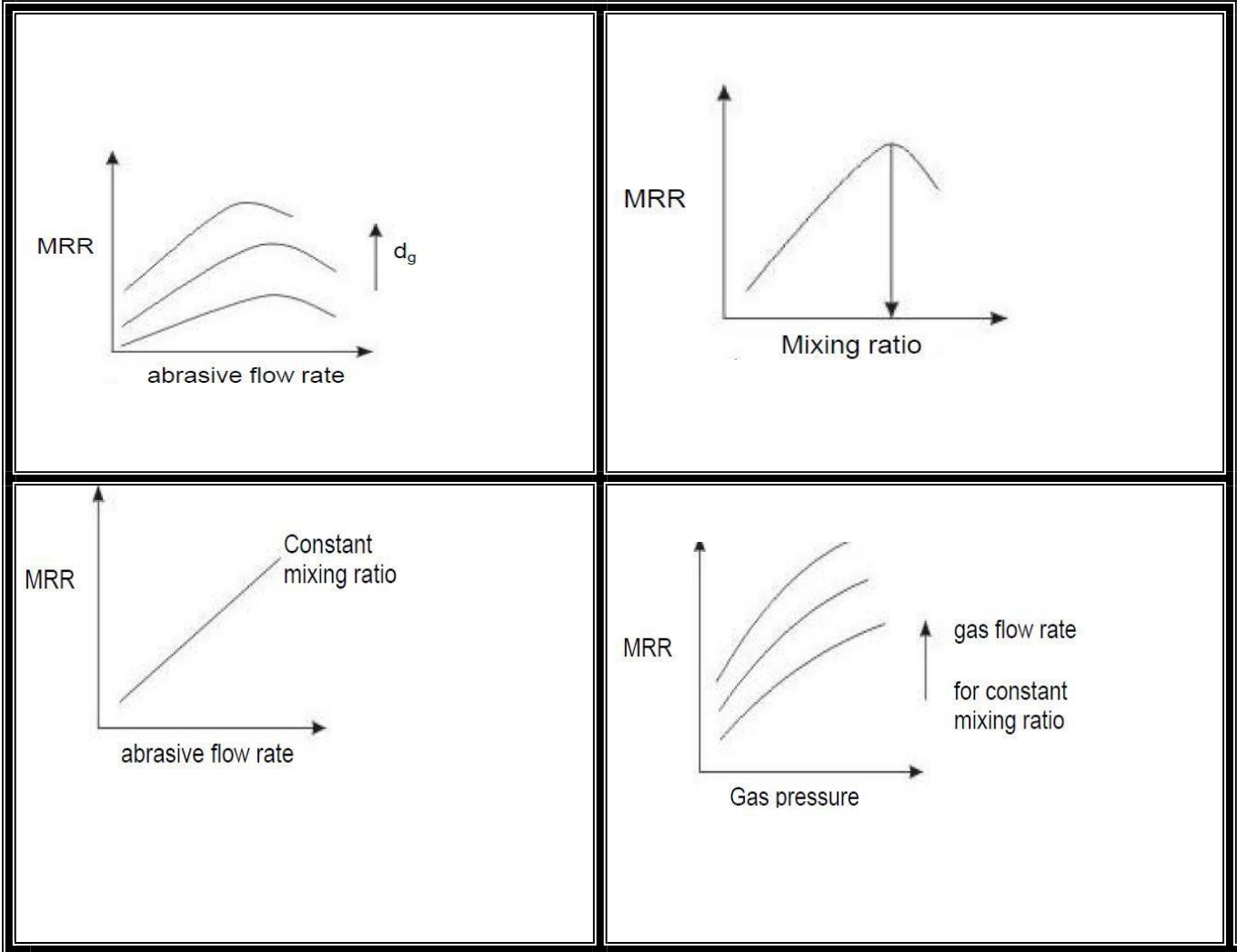

Fig.2-Operacting characteristics

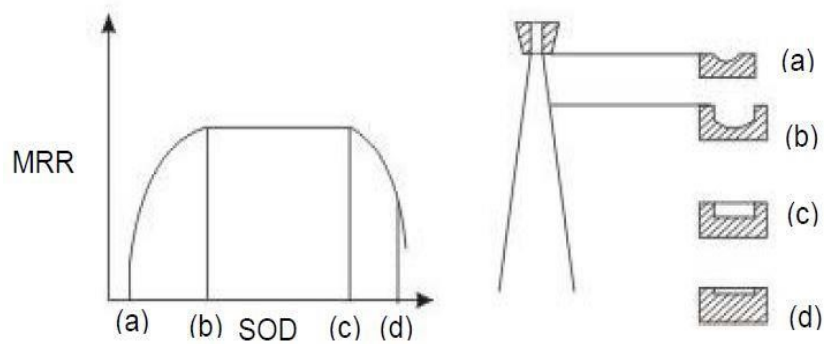
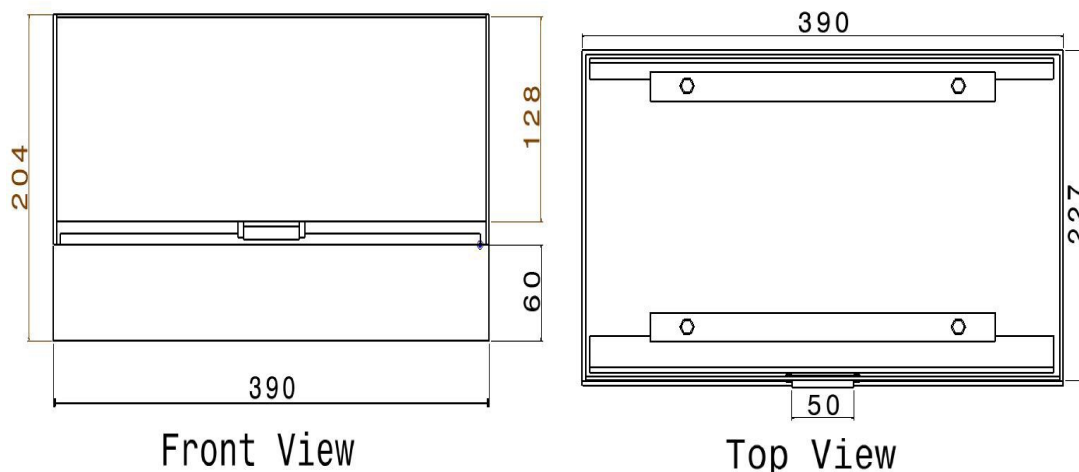

Fig.3 SODvs MRR

As seen in the graph MRR increases with increase in abrasive flow rate due to greater number of particles striking per unit time. Also MRR increases with increase in mixing ratio which is the ratio of weight of particles to that of the weight of air. But further increase in mixing ratio decreases MRR due to the fact that the volume of carries gas which is responsible for the high velocity is reduced. MRR increases with increase in abrasive flow rate when mixing ratio is constant. The MRR increases with increase in gas pressure as the particles will strike with greater velocity with higher pressure. Another important parameter is the stand-off distance which is the distance between the nozzle tip and work piece. As seen in the graph MRR first increase with increase in SOD then remains constant for a period of time and then decrease. This is due to the fact that flaring of jet occurs at a large distance from the nozzle tip. Also the shape of the cavity becomes less accurate as the nozzle tip distance increases.

VI. DESIGN METHODOLOG

An abrasive machine was fabricated in the institute workshop with required raw materials and procured components. Before that a detailed design of the functional subsystems were made using computer aided design tools. For this CATIA software was used which is very good in product design and analysis. The components that were designed include the machining chamber, work-holding device, nozzle and its holder, abrasive container and vibrating unit, cam and total piping system. Care was taken so to optimally use the material and space in the production engineering lab along with ease in using. The final components were fabricated in the workshop using the available materials like mild steel sheets bars and pipes, Aluminum sheets, rubber sheets, glass fiber, standard nuts and bolts etc. For fabrication purpose the welding machine, grinding machine, the hand-drill, sheet-bending machine, and shearing machines were used. Some components are procured from commercial market to improve accuracy.



MACHINING CHAMBER

Fig. 4-Machining chamber front view**Fig. 5-**Machining chamber top view

Sl. no	Material	Specification	Quantity	Resons for selection
1	Mild Steel sheets	1mm thick	880*440 mm	Good formability and weldability
2	Glass fibre sheet	5 mm thick	760*760 mm	Transparency and good visibility
3	Allen Bolts and nuts	6 mm 4mm	30 4	Easy operation
4	Hinges	Mild steel having 2 holes	2	Easy opration

Table 2-materials for machining chamber

VI. AIR TIGHT CHAMBER

The abrasive particles used in AJM are of very fine grit size and can be remain suspended in the air for very long time. Normally it is injurious to health if inhaled. So proper care has to be taken to prevent it from mixing with the atmosphere and dispose it. For this purpose the chamber was made air tight by application of suitable methodology. At first mild steel sheet of 1 mm thickness was taken and was converted into a one side open box with bending, shearing, cutting and welding operations. Mild steel sheet was chosen as it has excellent formability along with weld ability Different holes were made at appropriate places so as to accommodate the outer transparent glass fiber sheets. Transparent sheets were chosen so as to increase the visibility of inside machining process.

As the machine has travel in both X and Y directions it is difficult to cover the upper face of the chamber. For making it air tight transparent polythene sheet was used with required allowances of bed travel. The edges of the sheet were round folded and a spring was inserted in the passage .Then the spring was secured to the outer glass fiber sheet thus making the chamber air tight.

VII.WORK HOLDING DEVICE

In the AJM machining process the most common work pieces are glass sheets, glass fiber sheets, ceramic slabs etc. due to their brittleness. Material removal rate is lesser in ductile material due to the fact that ductile materials try to get embedded in the work material. For securing the work piece in its place L shaped angle plates was used with holes drilled on them long their length. The work piece also has the holes drilled in it so that both the plate and the work piece can be bolted together making it fixed. The L-plates were bolted to the mild steel box. The main advantages in this type of work holding system is that it can handle various sizes of work pieces by attaching various plates. The maximum work piece size that can be handled is 380*180 mm.

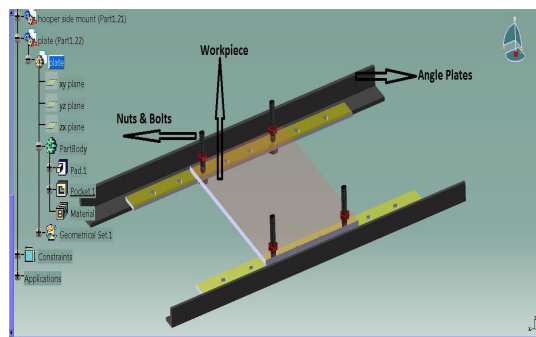
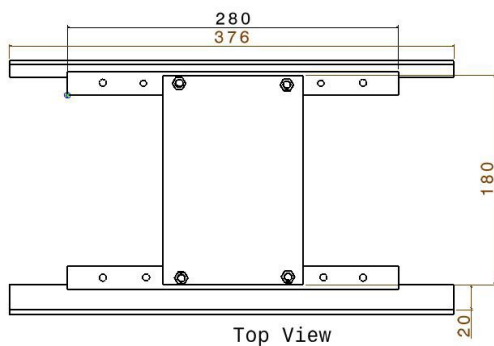

Fig. 8-Work holding device

VIII. OPENING & CLOSING SYSTEM

For opening and closing of the chamber hinge joint was provided for simplicity. The front panel of glass fiber can be opened by this method. The hinges were of mild steel material and light weight in nature. They were secured to the mild steel box by nuts and bolts. For tight closure of the wall magnetic clamps were used. They come in as a combination of the magnet and steel part in which the magnet can be secured to a fixed wall and the steel plate to a movable door or plate. After they come in contact the magnet holds it tightly. As there is a chance of leakage of air + abrasives through the gap between the metal and glass fiber a rubber strip was provided on the plate periphery.

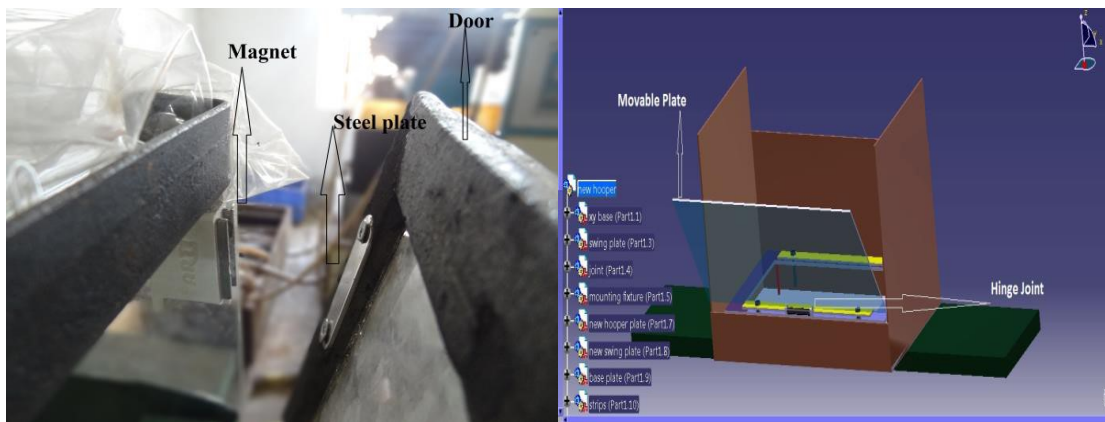

Fig-9 Magnetic clamp Fig-10 Door opening mechanism

IX. ABRASIVE DRAINAGE SYSTEM

The abrasive particle carried in high pressure air stream should be disposed safely otherwise they will get accumulated and hence create problems further. For safe drainage of particles a two way sloped passage way was provided. The passage was made of aluminum sheet which has a slope in both x and y direction and bent in such a way that the particles move to a corner and find their exit. The exit is of a 15 mm diameter pipe arc welded to the mild steel box.





Fig.11 abrasive drainage system

X. AIR & ABRASIVE DELIVERY SYSTEM

10.1 Air compressor

Air compressors compress the air to high pressure taking input energy from electric motor or internal combustion engine. In abrasive jet machining high pressure air jet is required so that the suspended particles in it can strike the work piece at high velocity. Positive-displacement air compressors work by forcing air into a chamber whose volume is reduced to compress the air. Piston type compressors use this principle by pumping air into an air chamber through the use of the motion of pistons. They use one-way valves to direct air into a chamber, where the air is compressed. Rotary screw compressors also use positive-displacement compression by mating two helical screws that, when turned, send air into a chamber, whose volume is reduced as the screws turn gradually. Vane compressors use a slotted rotor with varied blade placement to lead air into a chamber compressing the volume. The applications of compressors are to supply high-pressure air to fill gas cylinders, to supply moderate-pressure air to a submerged surface supplied diver, to supply moderate-pressure air for driving some and school building pneumatic HVAC control system valves, to supply a large amount of moderate-pressure air to power pneumatic tools, to fill tires, to produce large volumes of moderate-pressure air for large-scale industrial use such as oxidation for petroleum coking or cement plant bag house purge systems. For this purpose a compressor with capacity 50 bar powered by electric motor is used. The electric motor has the specification as follows. Power-3 HP, speed 1415 rpm, 3 phase induction motor.

10.2 Mixing chamber

The high pressure air from the compressor is passed through a FRL unit to remove any impurities. Then it is fed to the abrasive chamber which has one inlet for the incoming compressed air and outlet for mixture of abrasive particles and air. The abrasive particles are introduced from the side so to form a cyclone to facilitate better mixing. The chamber is of cylindrical shape made up of mild steel.

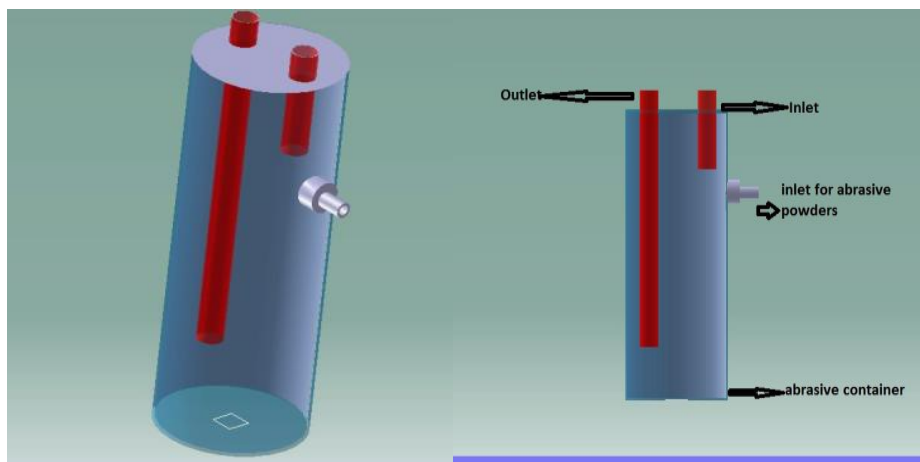

Fig.12 mixing chamber

10.3 Vibrating assembly

The vibration of abrasive container is required for the through mixing of the abrasive particle and air. The vibration is made capable by rotating cam action. The cam is connected to the electric motor and touches the end of the abrasive container. The container is hinged to an extension made out of the base. The abrasive flow rate can be varied by varying the speed of the motor. The whole system is made up of mild steel material in the institute worksho



Fig.-13 Vibrating assembly

10.4 FR unit

FR stands for filter regulator which is necessary for filtering the air and regulating the pressure. The common impurities suspended in the compressed air are dust particles of various sizes, moisture, and oil particles. Excess moisture present in the pipeline may result in coagulation of particles and jam the nozzle opening. Air filters have a porous membrane having various pores sizes like 5, 10, or 15 μm . They block the particles larger than the pores.

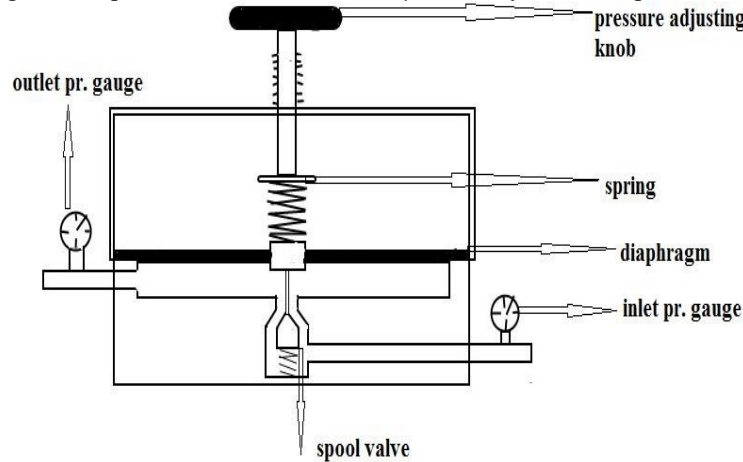

Fig.-14 Pressure regulator working

The line pressure is regulated by pressure regulator. A pressure regulator has a restricting element, a loading element, and a measuring element. The restricting element is a type of valve. It can be a butterfly, valve globe valve, poppet valve, or any other type of valve that is capable of operating as a variable restriction to the flow. The loading element applies force to the restricting element. It can be a simple weight, a spring, a piston actuator, a diaphragm actuator in combination with a spring. Here a single-stage pressure regulator, a force balance is used on the diaphragm to control a spool in order to regulate pressure. With no inlet pressure, the spring above the diaphragm pushes it down on the spool, holding it open. When inlet pressure is introduced, the open spool allows flow to the diaphragm and pressure in the upper chamber increases until the diaphragm is pushed upward against the spring force, causing the valve to reduce flow, thus stopping further increase of pressure. By adjusting the top screw by rotation, the downward pressure on the diaphragm can be enhanced, requiring more pressure in the upper chamber to maintain equilibrium. In this way, the output pressure of the regulator is controlled within a safe limit.

10.5 Nozzle and holder

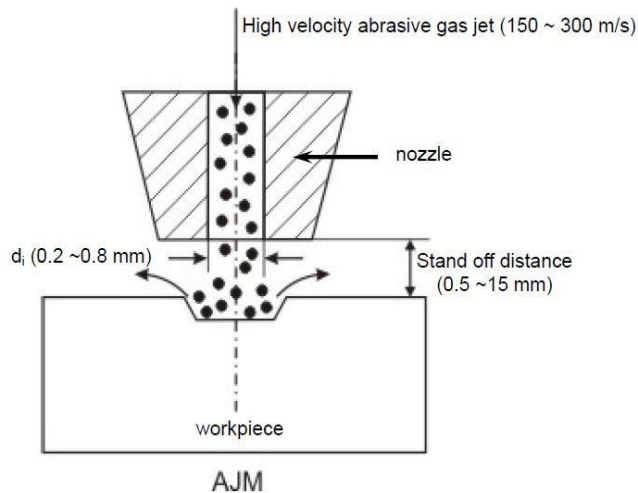

Fig.15 abrasive nozzle operation

Nozzles are the mechanical devices which increase the velocity of fluid in exchange of pressure drop. They are commonly used in internal combustion engines, space rockets, missiles, fire extinguishers etc. In abrasive jet machining the high velocity jet is created by the nozzle action. As the abrasive particles strike the nozzle they may erode the nozzle surface. So very high wear resistant materials such as tungsten carbide and sapphires are used. Tungsten carbide nozzles are used for circular cross-sections in the range of 0.12-0.8 mm diameter, for rectangular sections of size 0.08 x 0.05 to 0.18 x 3.8 mm and for square sections of size up to 0.7 mm. Sapphire nozzles are made only for circular cross-sections only. The size varies from 0.2 to 0.7 mm in diameter. Nozzles are made with an external taper to minimize secondary effects due to ricocheting of abrasive particles coming out. Nozzles made of tungsten carbide have an average life of 12 to 30 hours whereas nozzles of sapphire last for about 300 hour of operation. The rate of material removal and the size of machined area are influenced by the distance of the tip nozzle from the work piece. The abrasive particles from the nozzle follow a parallel path only for a short distance and then the jet of particles flares resulting in the oversizing of the hole. It is observed that the jet stream is initially in the form of a cylindrical shape for about 1.6 mm and then it flares into a cone of 7° included angle. The material removal rate initially increases with increase in the distance of the nozzle from the work piece because of the acceleration of particles leaving nozzle. This increase is maximum up to a distance about 8 mm and then it steadily drops off because of increase in machining area for the same amount of abrasive and decrease in velocity of abrasive stream due to drag. Despite their simple design, abrasive jet nozzles can be troublesome at times. The main drawbacks are short life of expensive parts, clogging of orifice due to dirt or moisture, wear, miss alignment and damage to the jewel.

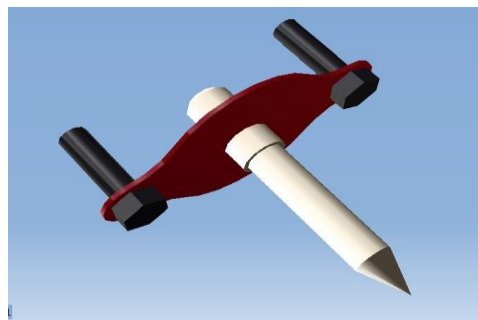
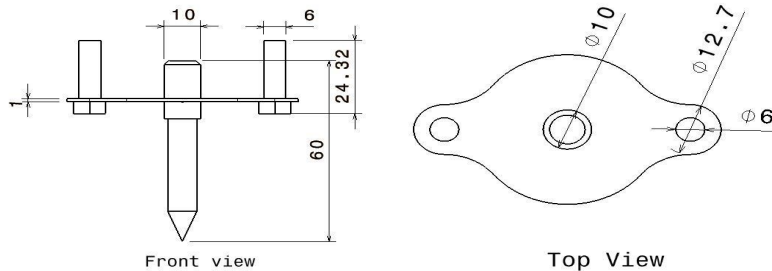

Fig. 16 Nozzle holder

Three nozzles having orifice diameters 0.6, 0.8 and 1 mm are used to facilitate the variation of parameters. The nozzle material is tungsten carbide. They are procured from outside to increase the efficiency and accuracy. The nozzle holder is made up of mild steel plate having a 10 mm dia. hole to accommodate the nozzle. It is secured to the frame by two Allen bolts on both sides.

10.6 Piping systems

The piping systems are required for carrying the compressed air from the compressor to the mixing chamber and from the mixing chamber to the nozzle orifice via the filter regulator. It is required to maintain the pressure in the line without eroding the pipe. Here nylon braided hoses having 12 mm internal dia. is provided. This is used because of long life, light weight, durability and easy availability. Also the head loss is very

small when it occurs a bend. The hose is composed of reinforcement of synthetic yarn in between two or more layers of soft PVC. The yarn is reinforced in longitudinal directions as well as crosswise so as to increase the strength.



Fig. 17 –Braided hose pipe Structure

XI. MACHINE FRAME AND X-Y-Z TRAVEL SYSTEM

11.1 Machine frame

In the fabrication of AJM machine care has been taken to use available materials and old but functional equipment to reduce cost. Here the frame of the machine is taken from an old CNC milling machine from where the arbor, tool holder, LCD display, coolant pipe, light etc. are removed. To machine's C-column is used for holding the nozzle assembly. The whole machine is mounted on a table. By this way the vibration is reduced and stability is maintained.

11.2 X-Y-Z travel system

X-Y table is the most important part of the AJM over which the machining chamber has to be kept and machined. The travel of X-Y table is 290 x 170 mm. the various functional components of the x-y travel systems are LM guide way (2 pairs-4 nos.), Ball screw (2 nos.) Support unit (2 fixed & 2 supported), Nut bracket (2 nos.), Couplings (2nos.), Standard nuts and bolts. The X-Y table consists of two parts, (a) Upper table, (b) Lower table. The upper table is for x- movement and has a travel of 290 mm. The lower table has a travel of 170 mm and is responsible for the y- motion of the work.

LM-Guide is used for highly precise linear motion. It can sustain high loads in multiple directions and hence can be mounted in any direction. The assembly contains a rail which guides a block on it. Inside the block, ball or roller are present which drastically diminishes the frictional losses. Hence LM-Guide is preferred in both industries and robotics to achieve specific functions. Advantage of LM guide are smooth movement with no clearance high running precision with ease, high rigidity in all direction, high permissible load rating, high long term precision, high speed operation. Circular ball screws are used in between the screw and nut to greatly reduce the friction present.

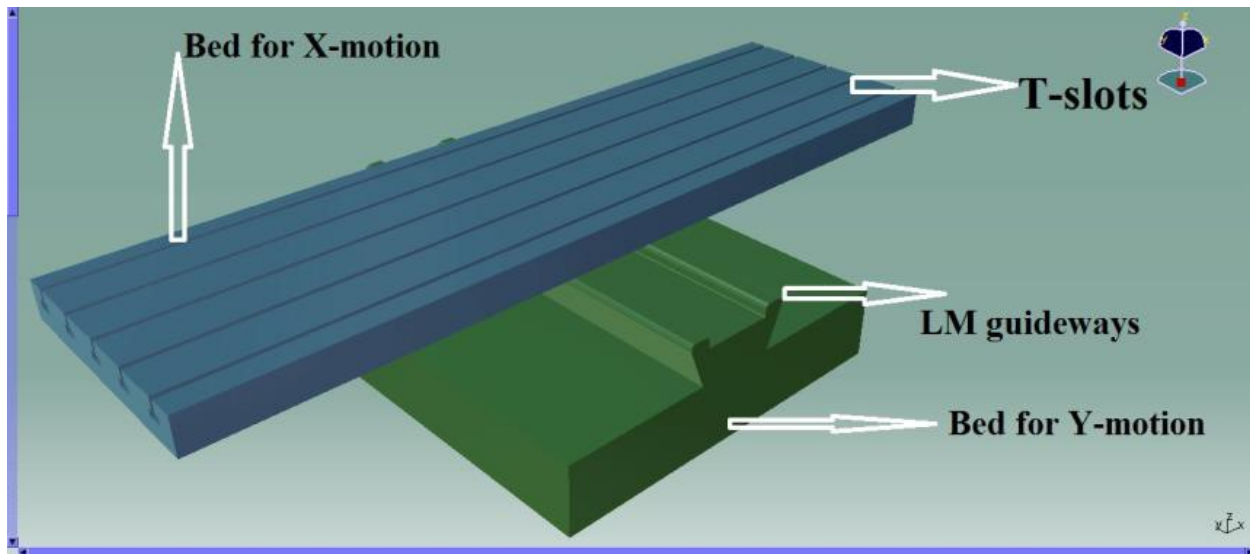

Fig. 18 X-Y table

XII. MACHINE AUTOMATION

The AJM machine is automated to have 3 axes motion using microcontroller and driver system.

The microcontroller generates the electronic pulses that are fed to the driver circuit. The motor driver circuits convert this signal to motion control for motor. This way the speed as well as direction of the motor can be controlled effectively. The microcontroller may take input from a computer or can be operated manually. Automation is required for less human involvement and to increase the accuracy and operation time.

12.1 Stepper motors

A stepper motor is a brushless electric motor that converts digital pulses into mechanical rotation. Every revolution of the stepper motor is divided into a discrete number of steps and the motor is sent a separate pulse for each step. The stepper motor can only take one step at a time and each step is of the equal size. As each pulse causes the motor to rotate a precise angle, the motor's position can be controlled without any feedback mechanism. As the digital pulses increase in frequency, the step movement changes into continuous rotation, with the speed of rotation directly proportional to the frequency of the pulses. Stepper motors are in both industrial and commercial applications because of their high torque at low speeds, low cost, high reliability, and a simple, robust construction.

There are three basic types of step motors variable reluctance, permanent magnet, and hybrid type. Also based on the number of poles excited at a time it may be unipolar or bipolar stepper motor. A stepper motor is used whenever controlled movement is required. There are two ways to connect a stepper motor, in series or in parallel. A series connection provides a high inductance and therefore greater torque at low speeds. A parallel connection will lower the inductance which results in increased torque at faster speeds. The stepper motor driver receives step and direction signals from control system and converts them into electrical signals to run the step motor. One pulse is required for every step of the motor shaft. In full step mode, with a standard 200-step motor, 200 step pulses are required to complete one revolution. The speed of rotation is directly related to the pulse frequency. Some drivers have an on-board oscillator which allows the use of an external analog signal or joystick or remote control to set the motor speed.

The rotary motion of a stepper motor can be converted to linear motion using a lead screw/worm gear drive. The lead, or pitch, of the lead screw is the linear distance traveled for one revolution of the screw. Finer resolution is possible by using the step motor/drive system in micro stepping mode. The main applications are printers, fax machines, high end office equipment, plotters, hard disk-drives, medical equipment, automotive and many more. Stepper motor "step modes" include Full, Half and Micro step.

In our machine three stepper motors are provided for three axes motion control. They are mounted to the beds and the column. The rotary motion of the motors is converted to linear motion by the lead screw arrangement. The specifications of motors are as follows:-

Sl no.	parameter	values
1	Steps	200 Steps/Rev,
2	Current	3.1 Amps
3	Voltage	2.9 V

Table-3- Steeper motor specifications

12.2 Controller and driver

Stepper motors can be operated at different speeds with the help of microcontroller with the precise angle because of the small step angle present in the motor

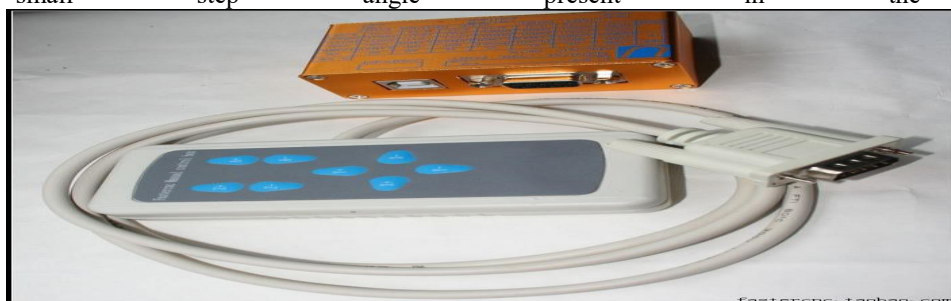

Fig.19- controller and remote

We have used USB6560T4 controller as it is of lesser cost and easily available. The main features are

- **4-axies on board, USB Interface.

- **8 limit switches is allowed to connect to the board, for every direction.

- **Additional control box i.e. a remote control is present which can be used to control without a computer.

TOTAL ASSEMBLY

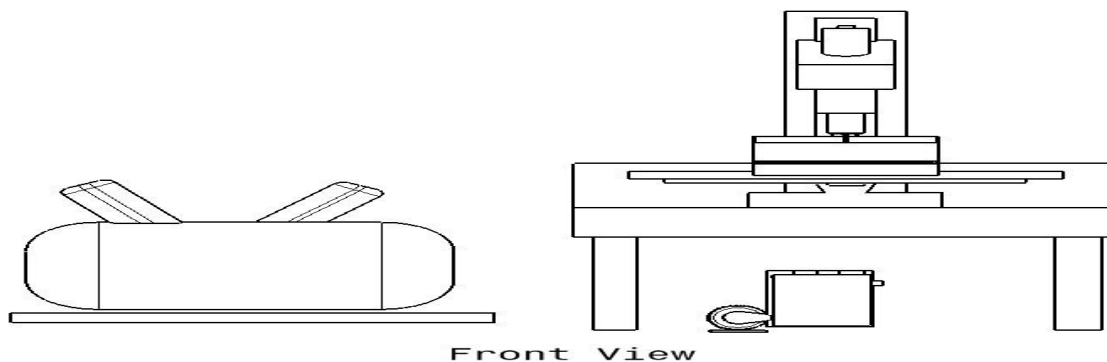

Fig.-20 Total assembly front view

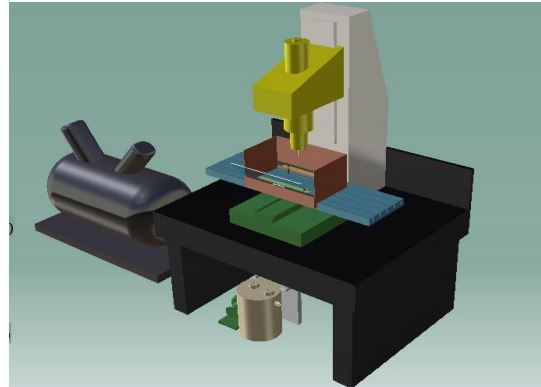
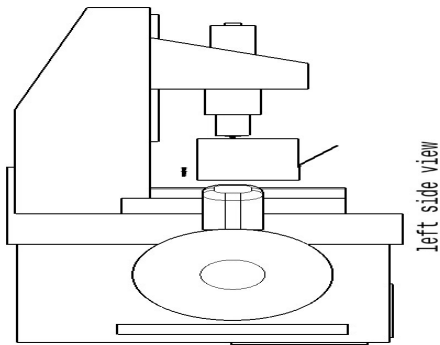

Fig.-21 side view Fig.-22 Isometric View

5. COST ESTIMATION

SI NO	NAME OF THE ITEM	COST PER SINGLE PIECE (Rs)	NO. OF ITEM	TOTAL COST (Rs)	
1	NOZZLE	2000	1	2000	
2	FR UNIT	5000	1	5000	
3	CNC CONTROLLER	11,000	1	11,000	
4	ELECTRIC MOTOR	2000	1	2000	
5	ABRASIVE POWDER	2000/500GM	2	4000	
6	GLASS FIBRE	500	1	500	
7	NUTS & BOLTS		50	750	
8	MISCELLANEOUS (PAINT, MS SHEETS, PIPINGS ETC.)			10,000	

9	TOTAL	35,250/-
---	-------	----------

Table-4 Cost estimation

XIII. CONCLUSION

In this project, a complete model of abrasive jet machine is fabricated in the institute production engineering laboratory. Before fabrication a complete CAD model was prepared for optimum use of material and space. Most of the components are made locally and sophisticated parts which affect the accuracy greatly are procured from outside. The machine is automated using micro-controller-driver-stepper motor combination. The machine can fabricate components taking inputs from a computer or can be operated manually. This greatly reduces human effort and improves accuracy.

REFERENCES

- [1] Production technology”, HMT publication
- [2] Elements of workshop technology”, S K HajraChoudhury, S K Bose, A K Hajrachoudhury, Niranjan Roy, Vol-II, Media promoters and media publications
- [3] “Modern machining process”, S Pandey and H N Shah, S. Chand and co.
- [4] www.thefabricator.com
- [5] www.sciencedirect .com
- [6] www.wikipedia.org
- [7] www.elgi.com
- [8] www.nptel.iitm.ac.in