

New Method of Transmitting Electricity

M. Bank

I. FOREWORD

The work presented below summarizes a number of new ideas for transition of electrical technology in accordance with a new concept. Briefly this concept can be formulated as follows: Any electrical transmission system can be built using a method of transmitting only one common current, or in another words one wire method named B-line [1, 2].

More than 100 years ago, Tesla proposed transmitting energy over a single wire at a high frequency (today is resonance method). Then came single-wire direct current transmission methods [1]. In addition, there are methods of transmission instead two wires using one wire, when the second potentials at the output and input of second wire are grounded (SWER system). All these systems have certain disadvantages [1], such as large losses in converters, signal emission, appearance of reactive power, impossibility of underground lying of wires, difficulties in synchronizing renewable energy sources with a trunk line

After B-line first publication seven years ago [1, 3], numerous objections were made. One of these objections was based on the opinion that since an electrical source and consumer have at least two output and two input wires, therefore it is not possible to use less than two wires.

The history of the development of technology shows that in the first period of any new technology revolutionary developments appear. Not all of them persist over time. However, the ideas obtained in the process of their research provide positive impulses for further development.

Take a several examples.

- This was the case with first supersonic aircrafts, such Concorde and Soviet Tu-144.
- The same happened with high-speed ground transportation. Even now modern high-speed trains in their normal operation develop speeds of up to 350-400 km / h, and in the tests they can accelerate even to 560-580 km / h.
- More and more electric cars come into life and a first cars driving without a driver already appeared.
- Electrical and hydrogen car engines generate a lot of hope for the future of transportation.
- In order to get rid of a wheel friction altogether, that is to make a train suspended over the tracks (non-rail guides or track), hovercraft trains with turboprop and turbojet engines were developed.
- Also trains on a magnetic levitation (maglev) with linear traction electric motors and superconductors enjoyed some distribution in the world.
- Stereo displays should be mentioned as well. They are designed to display information which creates for the viewer an illusion that the displayed objects have real volume and an illusion of partial or complete immersion in a scene due to the stereoscopic effect.
- Today it is believed that the only method that allows you to get a truly three-dimensional image is the use of holograms.

II. B-LINE METHOD IN PATENTS

But let us now come back to electrical transmitting systems.

The most expensive parts in electrical systems are wires. B-line method will allow making electrical systems 5 - 8 times cheaper than it takes place now. With this method it will be possible to remove the existing multi-wire systems on high supports and to replace them with one underground wire.

Transmitting electrical energy through one wire is not a trivial task. In all known multi-wires systems the input currents in different wires have different polarities or different phases. It is a serious problem to summing energy of these currents.

The same problems exist in an output. We have to receive several currents corresponding to a consumer structure. For solving these problems new ideas are needed to develop new methods and new constructions.

Let us consider these solutions which disclosed in patents.

US Patent No.9,608,441.

Patent deals with to two-wire systems with a single-wire electrical transmission line.

Abstract. A single-wire electric transmission line system that includes power sources having first and second poles and a phase shifting device, coupled to one of the poles of the power source, in such a manner that the phase shifting device shifts the phase of a first signal propagating through the pole such that the shifted phase of the first signal will be essentially identical to the phase of a second signal propagating through the other pole. The shifted first signal is added to the second signal with essentially the same phase of second signal, whenever both poles are connected together to form a single-wire, through which the resulting added signal propagates.

The input signal here is a usual two-wire signal, and the polarities in both signals are opposite. For achieving the same polarities a phase shifter or an inverter (a polarity changer) can be used. Now both currents can be summed.

If one needs to receive currents as an output, one must divide a common current into two equal currents and to include an inverter in one of them (see Fig 1). The inverter can be made by a transformer with oppositely connected windings. On high frequencies the inverter can be formed as a delay line with on half-wave length.

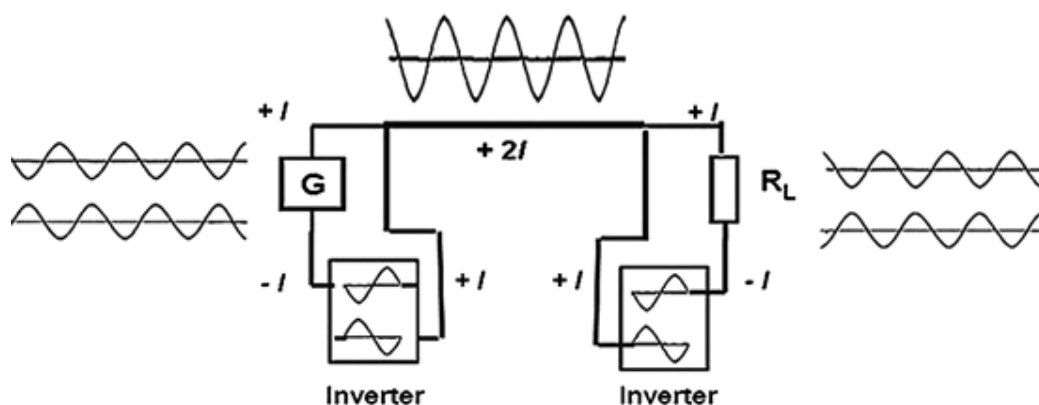

Fig 1. Two wire system transformed to B-L:ine.

US Patent No.9,246,405

This patent discloses an electrical energy transmission system with a single transmission line. It deals with three phase electrical systems.

In its abstract it is stated that an electrical energy transmission system has a three-phase electric current power source which generates a three-phase electric current having three electric currents, a converting device which converts the three-phase electric current to obtain a common electric current signal formed by summation of three electric currents having the same phases, and a single-line electrical transmission line which transmits further the thusly produced common electric current signal.

In this patent it is proposed to use phase shifts for receiving the same phases in all three currents. The formulas for this method are provided in the patent description. If one needs to use currents as input of two wires system one must divide a common current into two equal currents and to use converter in one of them (see fig 2)

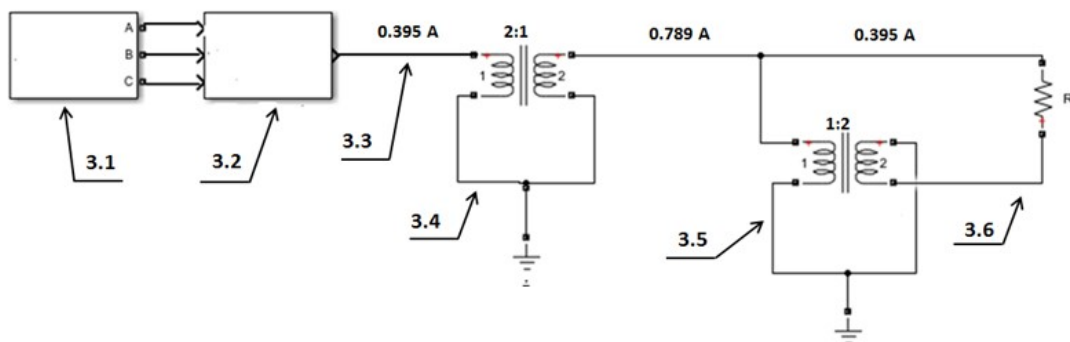

Fig 2. Three phases to two phases transform.

US Patent No.10,305,289

This patent discloses a phase converter for a vector conversion of three-phase electrical signals

It is stated in it that a phase converter for electrical signals is configured for obtaining a vector sum of phase signals or subdividing one signal into several phase signals, including transformers and configured for successive addition of signals received from secondary windings of the transformers and inversion of one or several of the signals, or for subdivision of the one signal into the several phase signals.

In an Abstract of this patent it is proposed and justified that for receiving one common signal instead three-phase signal one can summarize two signals from three phase signals and add a third signal from three phase signals after inverting (see Fig 3 left part before switch). As a result a current is received with amplitude two times more than an amplitude in each phase. This method including a more detailed description of a three phase output description in [6]

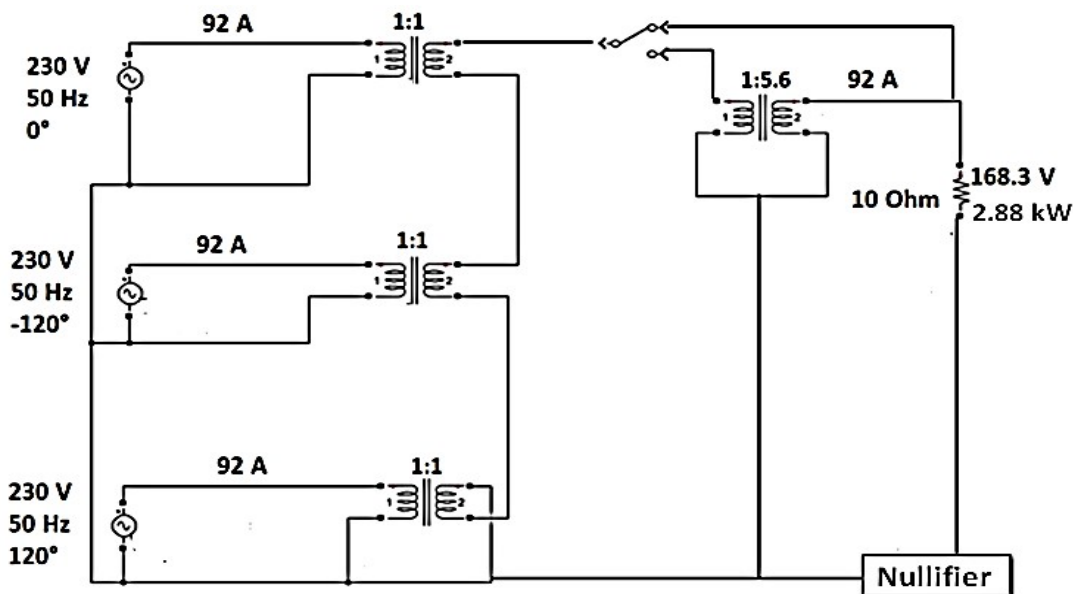

Fig 3. Phase convertor schema and two wires output.

US patent No.10,250,061

System for charging electrically drives vehicles with a single line for transmitting electric current from a source to a charging station.

The system disclosed in this patent solves a problem of fast charging of electric cars on a long road. One needs high voltage for fast charging, but it is difficult to find a high voltage on long roads. In the patent it is proposed to use in the beginning of road a one wire source with a high voltage and transmits this electricity in a wire under asphalt along the road. In any part of the road one can use a charging station, which can supply to the electric car in a different way a current including DC. In the end of road the last charging station must be provided.

US Patent Application No.17/317,508.

It discloses an electrical energy transmission system which does not require reservation.

It is explained in its Abstract that *an electric energy transmission system which does not need a reservation has a generator generating a multi-phase electric current, a converter converting it into another electric current, an electric current network connected with the converter and having a first group of electric current wires extending towards electric current users and a second group of electric current lines electrically connecting the electric current of the first group which each other, and plurality of consumer blocks connected with the network and having users which use different electric currents and further converters converting the electric current transmitted by the network into the different electric currents and supplying the different electric currents to the electric current users.*

With this solution one can use for reliably transmitted electrical current without a reservation, using several identical wires, each of them transmitting the same common current I . For this purpose a common wire is divided in M wires each of them for transmitting an electric current of value I/M . These wires are being laid with distance d between them. Therefore a common current is transmitted without using a common wire, but through several wires with a cross section M times smaller than that of the common wire. If any section is damaged, the current will continue to flow to the consumer through a detour.

III. COMMON PRINCIPLES OF BUILDING ONE WIRE ELECTRICAL TRANSMISSION SYSTEMS

Common principles of building one wire electrical transmission systems

The name of this wire and the names of such systems needed explanation. A one wire system or B-line system is a system which allows transmitting all signals by one current. However, one can divide a current into several equals' currents and transmit them through several wires. But this system will be B-line system also, because an arithmetical sum of currents here is a common current.

In B-line system can be relatively new blocks. There are inverters and converters. An inverter is a block which changes polarity of a signal. It can be made by a delay line with a length equals to a half of wavelength. At low frequencies, for example 50 or 60 Hz it is impossible. At 50 Hz the wavelength is equal to 6000 km. At these frequencies inverters can be made by a transformer with back-connected windings. One point of a first winding is connected to an opposite point of second winding. This point must be connected to a nullifier or a grounding also. This connection with the grounding does not mean that we have any energy losses. The current goes in a ground, but a ground resistance is near to zero [4]. Thus this current does not work.

The potentials of these points seem to be turning around zero.

The system which uses the B-Line method in charging systems must include connected with electric car converters 1 - 3 or 1 - DC.

In case of the connector 1 - 3 a three-phase rectifier is used in a car. Smaller losses we will occur with use of a converter 1 - DC (See Fig 4) if this corresponds to the charging input in the car.

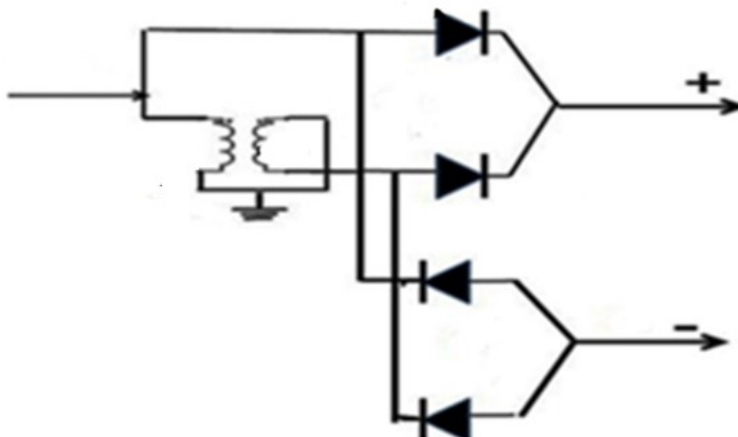

Fig. 4. Converter 1 - DC

The converter is a block which changes a quantity of wires in an input and an output for keeping a power of the signal.

For converting signals from several signals to one, it is necessary to equalize the phases of the input signals. After that these signals can be summated with one another. This process in a converter 3 – 1 is proposed in [9] (see Fig 3).

In B-line systems one can be use "one wires" transformer (see Fig 5). The second ends of windings must be with potential zero. For this one can use nullifier [9] or grounding.

All is written in this part can be summarized as following. Any complicated electrical system from current source till devise on kitchen can be made as B-line (see Fig 5).

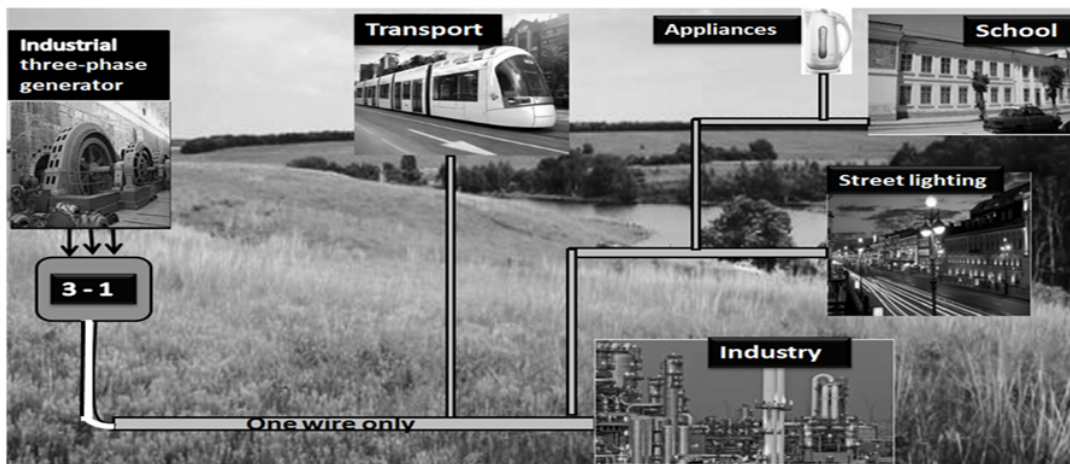

Fig 5. Fully single-wire system

In this system all branching, splitting and merging is simplified. Such a system is similar to the fountain park in Peterhof in St. Petersburg, where all the water is supplied through one pipe and diverges to all large and small fountains.

REFERENCES

1. Bank, M. It Is Quite Another Electricity: Transmitting by One Wire and without Grounding. Patridge. 2017
2. **Совсем другое электричество 2017.** <http://www.ofdma-manfred.com/wp-content/uploads/2016/06/SLE-Russian-10.-06.16.pdf>. Full-text available
3. Bank, M. (2012) New One-Way Line for Electric Transmission System. Journal of Energy and Power Engineering, 6, 1320-1327.
4. Bank, M. (2020) Zeroing Instead of Grounding. Journal of Energy and Power Engineering, 14, 33-37. <https://doi.org/10.17265/1934-8975/2020.01.004>
5. **Future Power Transmission System - IJNET**
<http://www.ijniet.org/uploads/2021/07/6.pdf> find <http://www.ijniet.org/wp-content/uploads/2021/07/6.pdf>
6. One Wire Is always Better Michael Bank, Vladimir Tsingauz Jerusalem College of Technology, Jerusalem, Kindlfind <https://www.scirp.org/journal/paperinformation.aspx?paperid=110110>
7. Can Electricity Be New? January 2020, Engineering 12(07):487-495, DOI:, [10.4236/eng.2020.127034](https://doi.org/10.4236/eng.2020.127034)
8. Electrical energy transmission system which does not require reservation. Patent Application N0 17/317.508. M. Bank
9. Bank, M. Zeroing Instead of Grounding. Journal of Energy and Power Engineering, 14, 33-37, 2020, <https://doi.org/10.17265/1934-8975>

Acknowledgments: The author is grateful my colleagues Galina Golant, Ely Zborovsky to the thoroughly English editing the article and two specialist in simulations Vladimir Thsingous and Your Shalyt.